

From **nanometer** to **hectometer**
we provide professional precision measurement solutions



Flash Measuring Machine
One-Touch Measurement





CHOTEST



Since established in 2002, Chotest Technology Inc. is focusing on the designing and manufacturing of precision dimensional measurement and calibration instruments.

With more than about twenty years of professional technology accumulation, Chotest has accumulated rich practical experience and set up a strong team who is specialized in optics, machinery, Electronics and information technology. At present, CHOTEST has more than 100 technology patents and software intellectual property rights. With competence in Micro-Nano motion, 3D Reconstruction of Micro-Nano measurement, 3D

Form and Surface Analysis of Micro-Nano measurement, Large-scale 3D Measurement, Precision Sensing Probe and Image processing technology, Chotest is capable to provide the customers with professional precision measurement solution from Nanometer to Hectometer.

Our products are widely used by public metrology labs and quality inspection workshops in the automotive, aerospace, machinery, metallurgy, power, and petrochemical industries. Chotest's service net is covering more than 30 provinces in China, and is also focusing on the development in overseas markets like Europe and APAC.

The goal of Chotest is to provide high-end dimensional measurement equipment to manufacturing industry all over the world.

One-Touch Measurement

Contents



VX8000 series

P.36-37



VX1000 series

P.38-39



VX4000 series

P.40-41



VX5000 series

P.42-43



VX8500

P.44-45



Hybrid series

P.46-47

Efficient measurement

- Auto illumination
- Auto focusing

5000+ pcs

Once up to 5000+ features

1024 pcs

Once up to 1024 workpieces

2 secs

In 2 seconds Finish the measurement

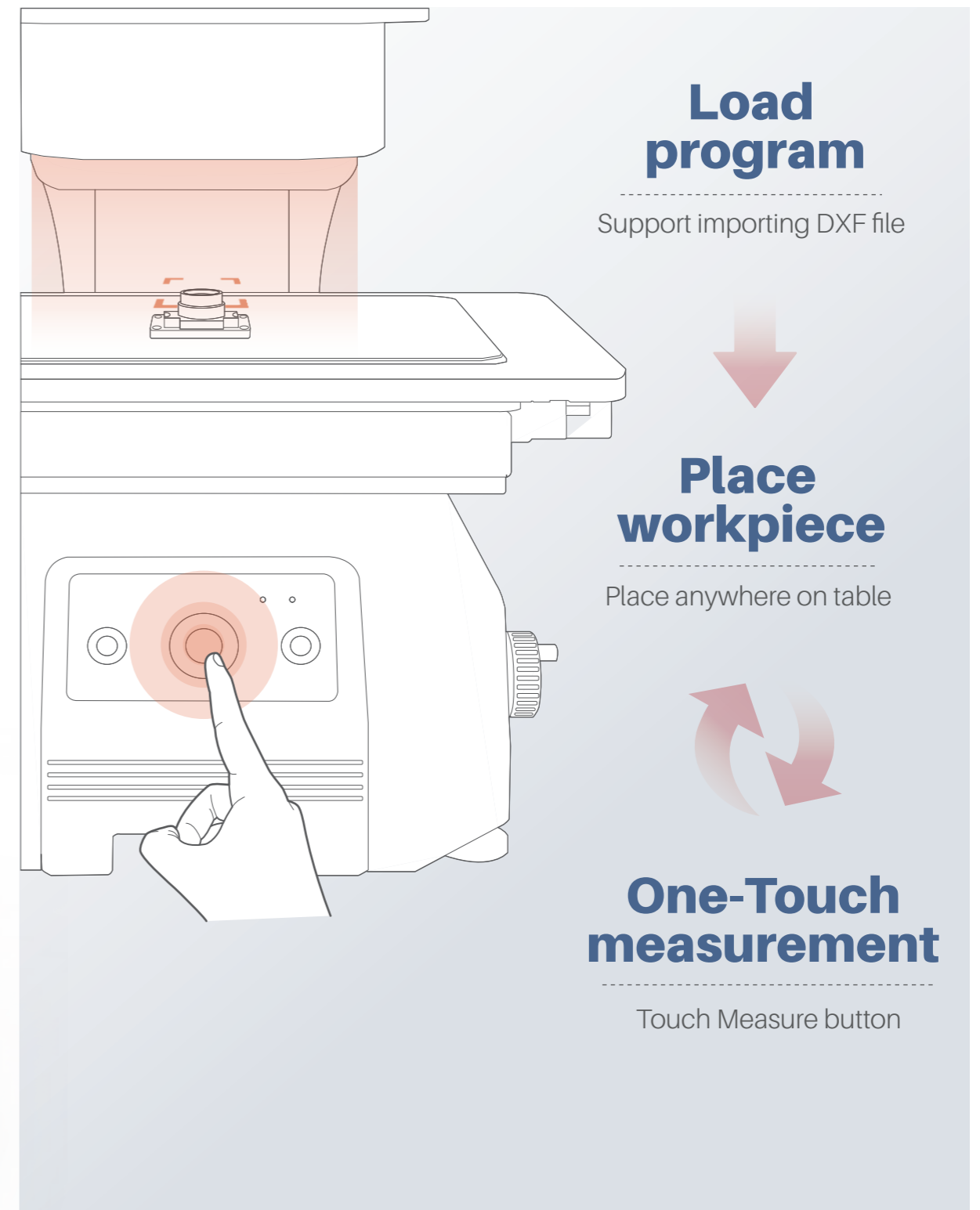

Dedicated Optical Lens

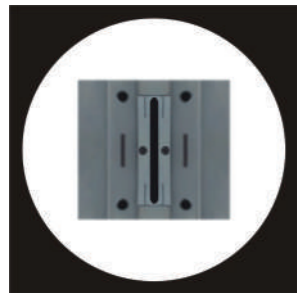

Normal Lens

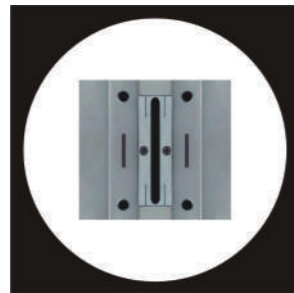

Our Dedicated Lens

Clear image even if there are stages

Equipped with a high depth optical lens and automatic focusing, the flash measuring machine only needs to focus at the tested object once. Even if there are variations in height, the images remain clear.

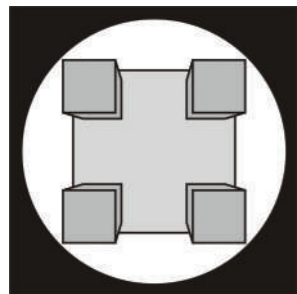

Normal Lens

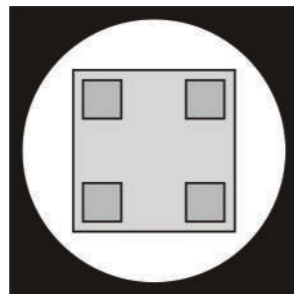

Our Dedicated Lens

Always real size even if there are stages

With a double telecentric optical lens, the size of objects in the image is always real and accurate, even features that are located at edge of the field of view.

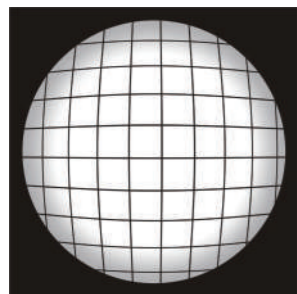

Normal Lens

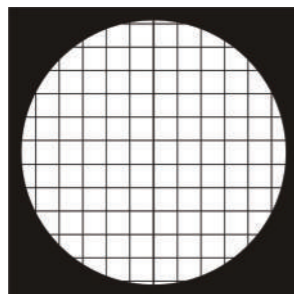

Our Dedicated Lens

Zero distortion in the full field of view

Thanks to the double telecentric optical lens with high depth of field and high resolution, it is almost zero distortion of the image in the full field of view. Test result is always the same in any position of the object table.

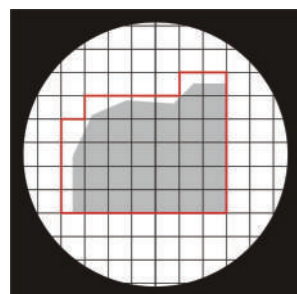

Normal Lens

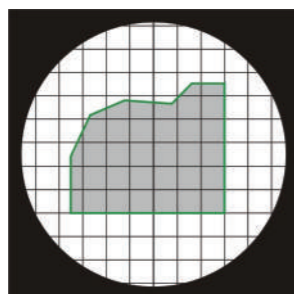

Our Dedicated Lens

Sub-pixel processing of edges

With algorithms of high-order interpolation and numerical fitting, the software can perform sub-pixel processing of the edges.

Light Source

Back light

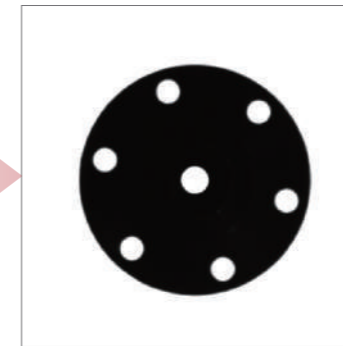

Coaxial light

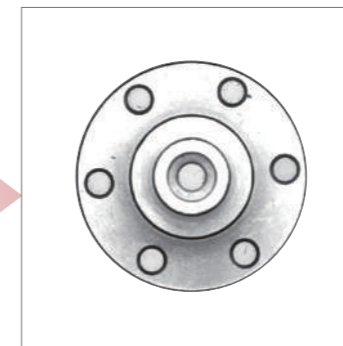

75° Ring light

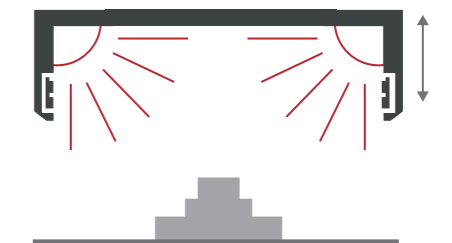
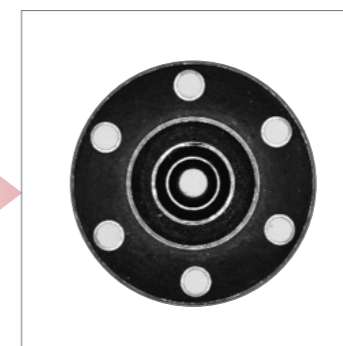
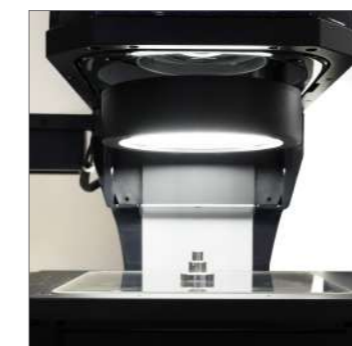

Height probe

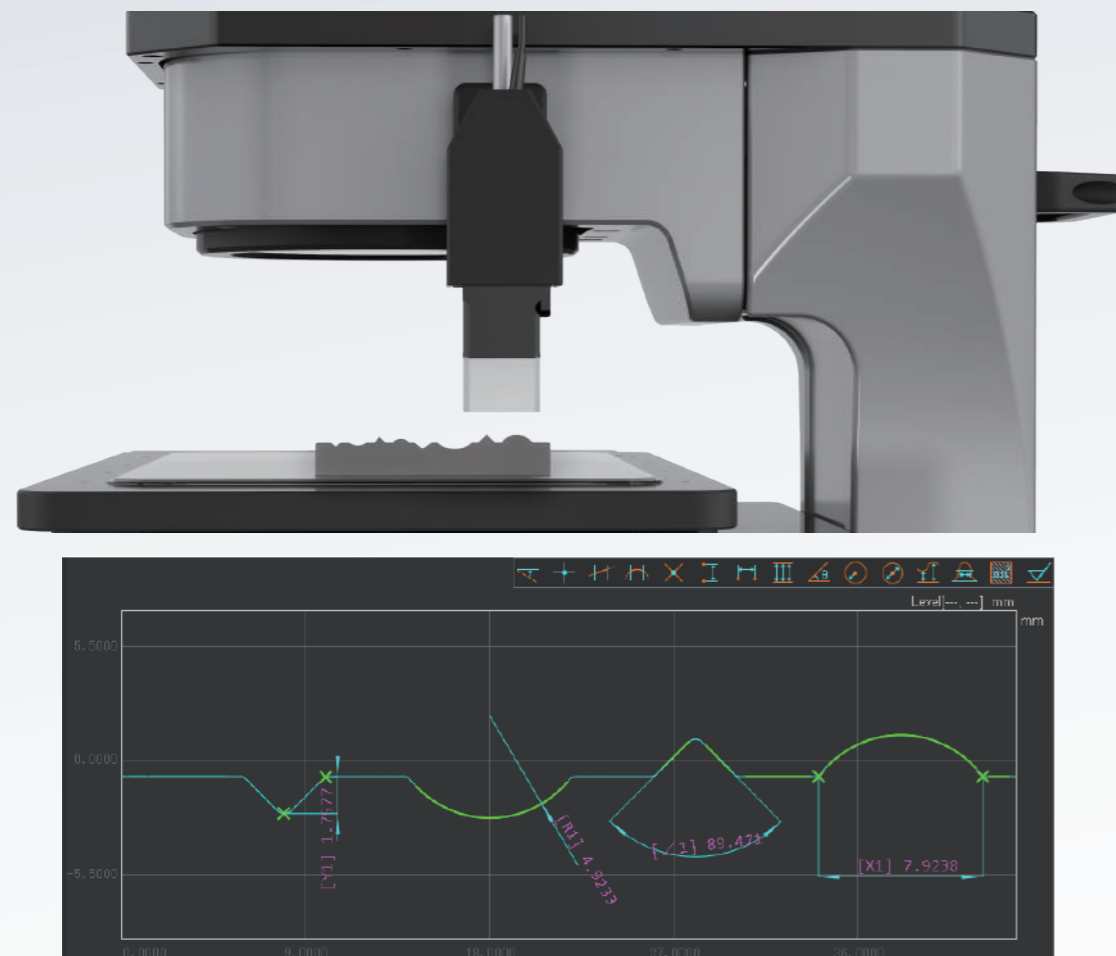

It is a white light confocal probe, and can be used to measure thickness, height difference, flatness, parallelism, etc. Moreover, this probe can scan the surface of the sample continuously.

Rotary chuck

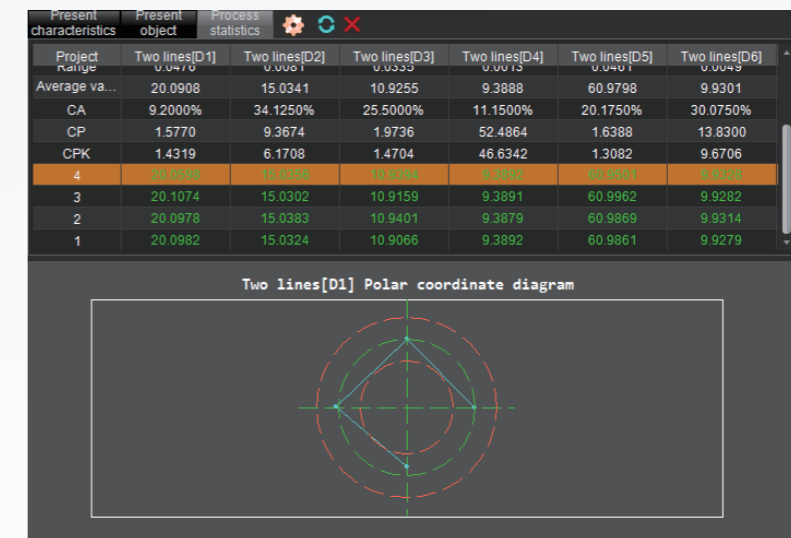
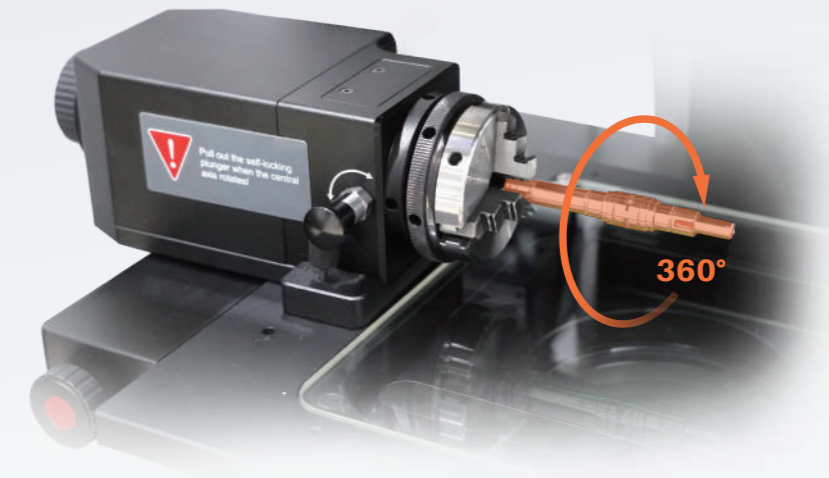

Rotary chuck can rotate 360°. It is convenient to measure the sizes in different section according to rotation angle specified by the operator. It is an ideal solution to measure all kinds of cylindrical parts, such as shaft, etc.

Software

Vision X professional visual measurement software is completely independently developed by CHOTEST, and CHOTEST has independent intellectual property rights. VisionX has friendly user interface, convenient operation, powerful and practical functions, support more than 80 kinds of extraction and analysis tools, including feature extraction tool, auxiliary tool, annotation tool and special application tool, etc. Moreover, functions can be customized according to user's need, so as to improve work efficiency more effectively.

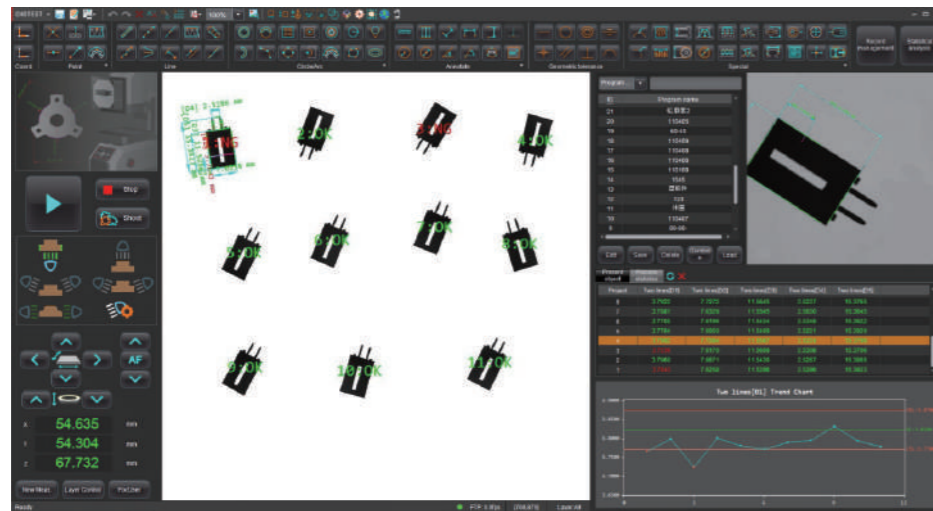

Home Interface

Features

Geometric Tolerance	Straightness, Roundness, Concentricity, Symmetry, Positional Tolerance, Parallelism, Perpendicularity, Profile Tolerance, etc.
CNC Mode	Modify CNC program anytime, as well as adding or reducing features OK or NG is concluded according to tolerance in CNC program
Automatic	Only need to select the measuring features, after placing the workpiece, measuring results can be obtained quickly by one key
Coordinate System	Can create coordinate system by Point-line, Line-line, and translate & rotate coordinate system, as well as create multi-coordinate system
Special tools	Rounded corner, Contour, Thread, Slot, Perimeter, Pitch distance, Thickness, Chamfer, Spring, Gear, Sealing gasket, area, Pitch Angle, Boundary width

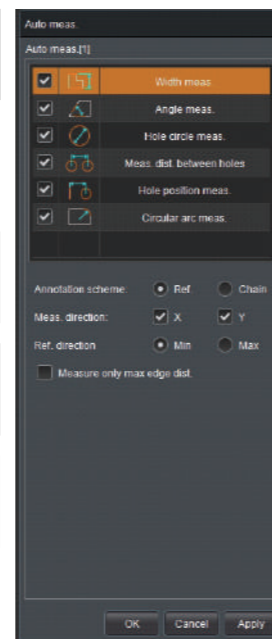

DXF Import

Measurement data can be obtained from CAD drawings. Even if the test object is not physically available, you can still create measurement programs quickly. The system can automatically assign features and dimensions from the DXF drawing to the sample, including surface dimensions

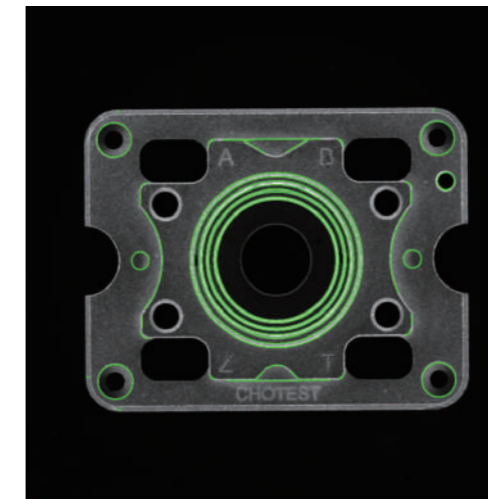

Sample

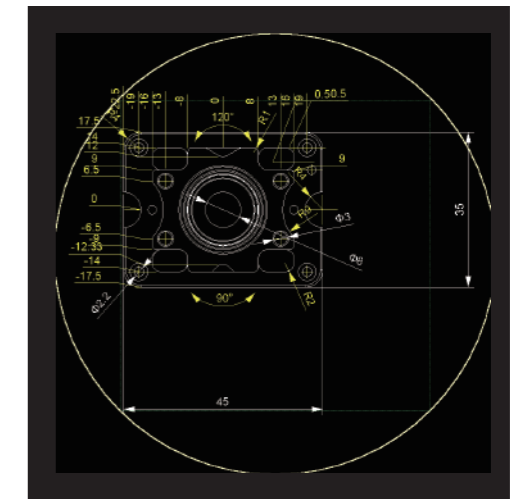

Automatically assign DXF features to the sample

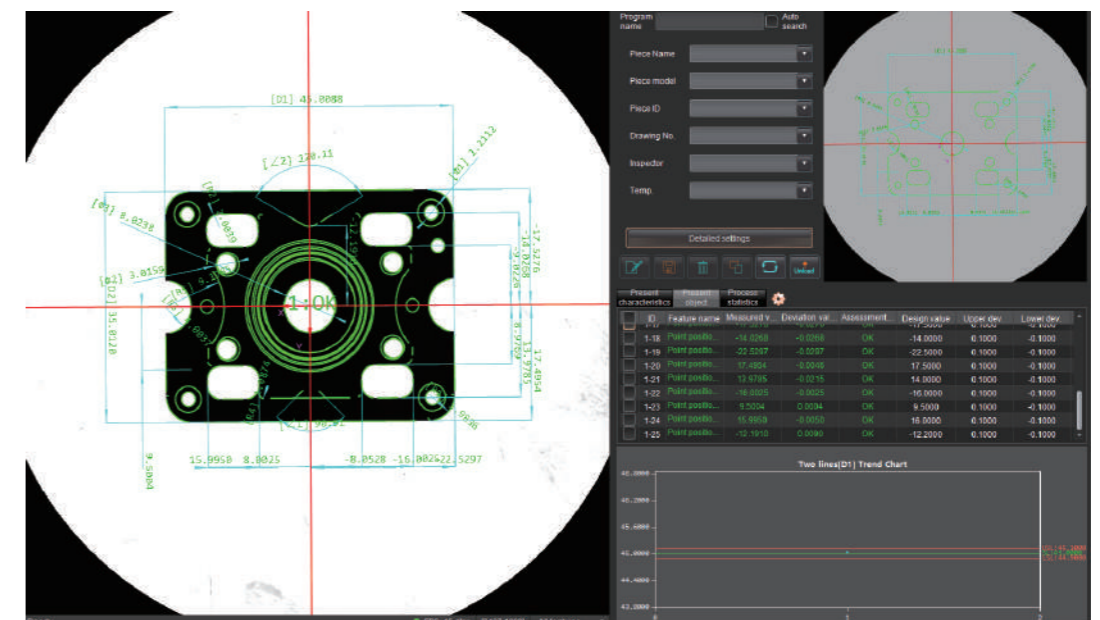

CNC Measure

Profile Tolerance

- This tool has three evaluation methods: No reference (only shape error evaluation), Single reference, Multiple references.

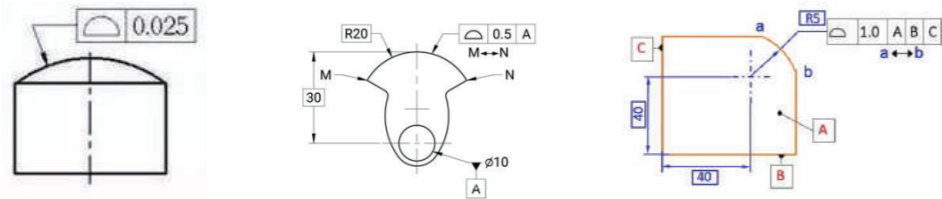

- Multiple annotations: Multiple profile tolerance can be annotated in a single program. No need to establish a coordinate system: Just need to enter the reference in the drawing. Measurement of profile tolerance in different coordinate systems can be achieved in a single program.
- Multiple types: Evaluate the profile tolerance by scanning the entire profile; Or evaluate the profile tolerance by measuring point with specifying coordinate values.

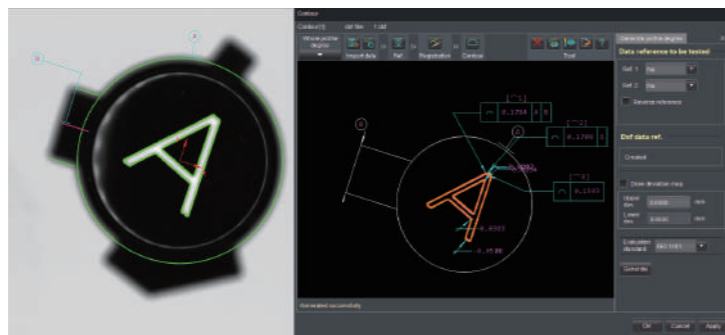

Position Tolerance

It can measure both point position tolerance and line position tolerance. Evaluation can be performed by XY coordinates in Cartesian coordinate system or radius & angle in polar coordinate system.

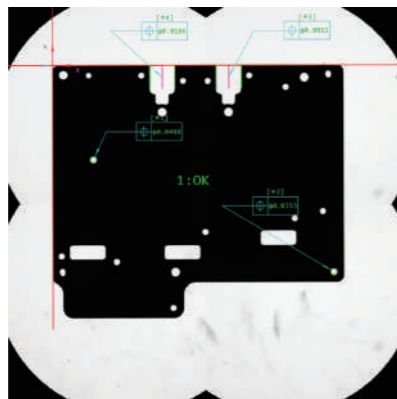

QR Code Recognition

The QR code on the sample can be defined as inspection information.

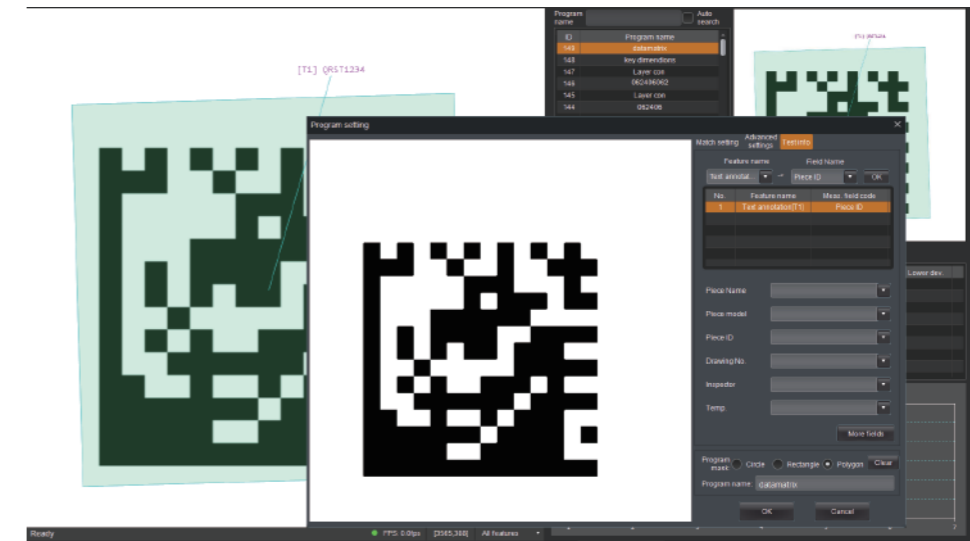

The QR value which is recognized by the software can be saved as inspection information during CNC measurement according to pre-setting.

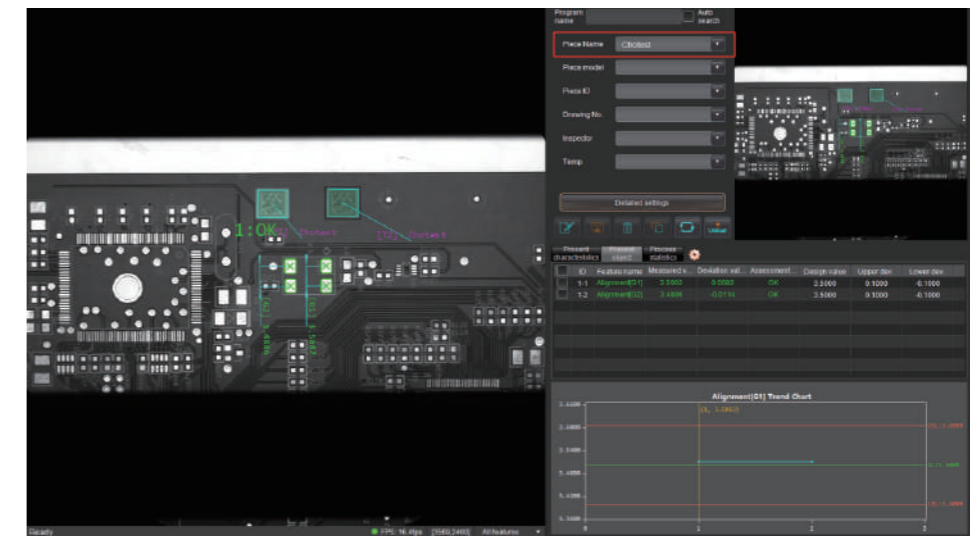

Automatic Multi-Object Matching

The system supports automatic measurement of multiple objects, up to 1024 objects at a time. 360-degree rotation search function, tested objects can be easily recognized and automatically measured, regardless of their orientation. The measurement sequence of the samples can be customized.

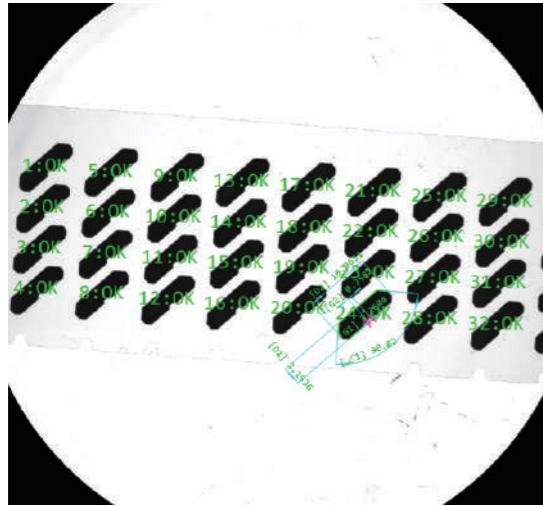

Z-order numbering

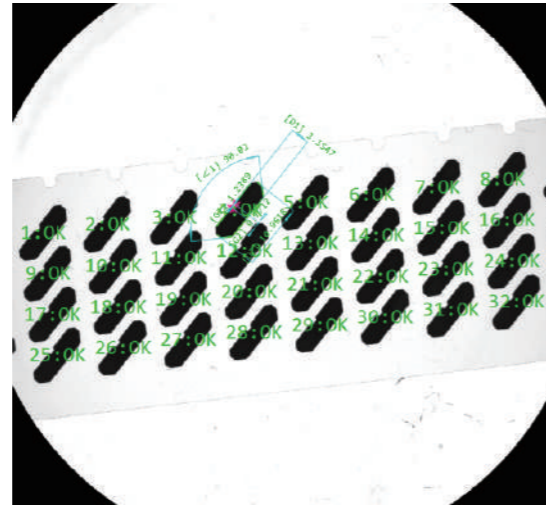

N-order numbering

Extract Multi-Circle by Lasso

When there are many circles located together on a sample, extracting circles one by one can be time-consuming and labor-intensive. This tool allows the diameter of the circles to be quickly extracted and annotated all at the same time.

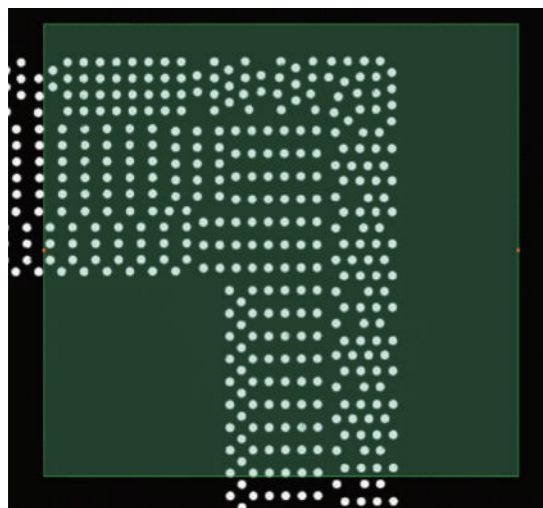

Before posture adjustment

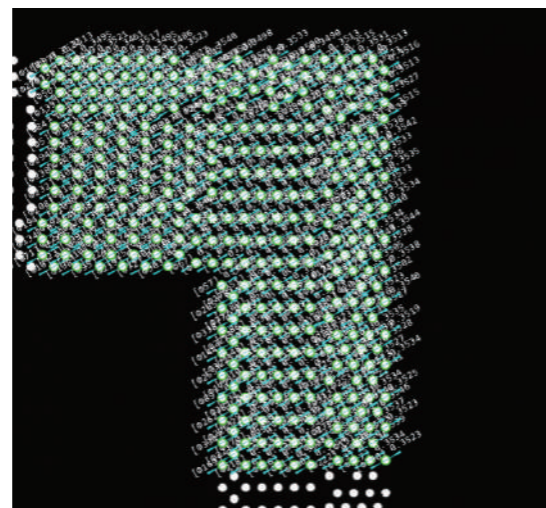

After posture adjustment

Fixed Position Measurement

Fixed position measurement eliminates the matching process, and the tested objects need to be placed in the same position. During CNC measurement, only images of the measurement areas are captured, greatly enhancing measurement efficiency.

Even for samples with significant deformation, such as rubber seals, automatic CNC measurement can be achieved through fixed position measurement.

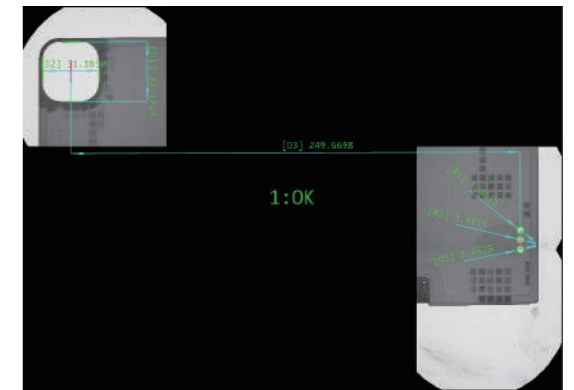
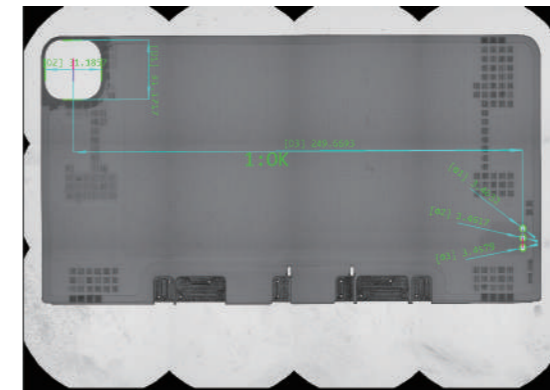

Seal Measurement

Accurate measurements can be performed even for seal rings with large deformations.

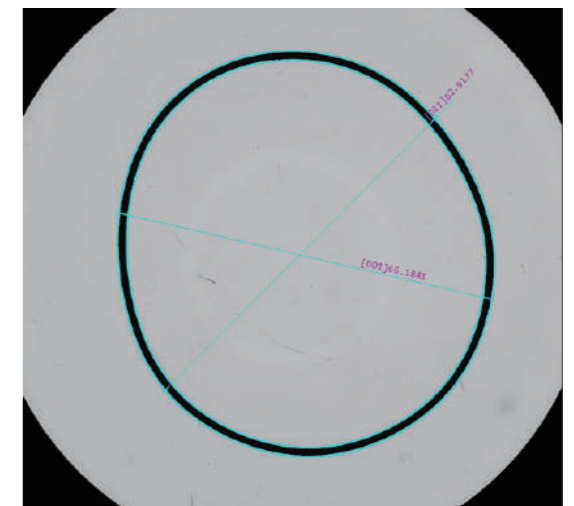
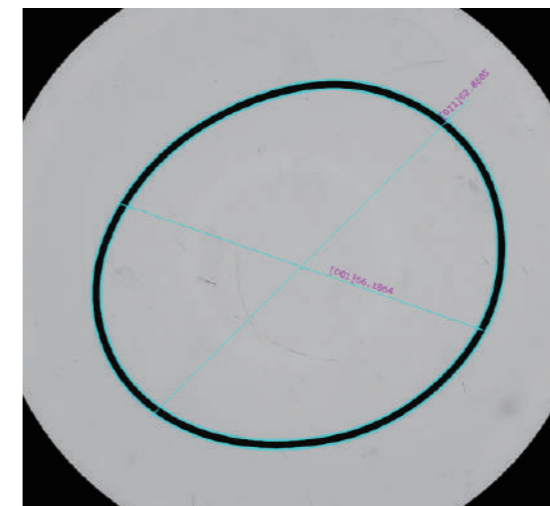

Conjoint program

Combine Wide F.O.V. and High Precision F.O.V. : Wide F.O.V. mode allows efficient measurement for large dimensions. High precision F.O.V. mode focuses on small dimensions of the test object, ensuring accuracy.

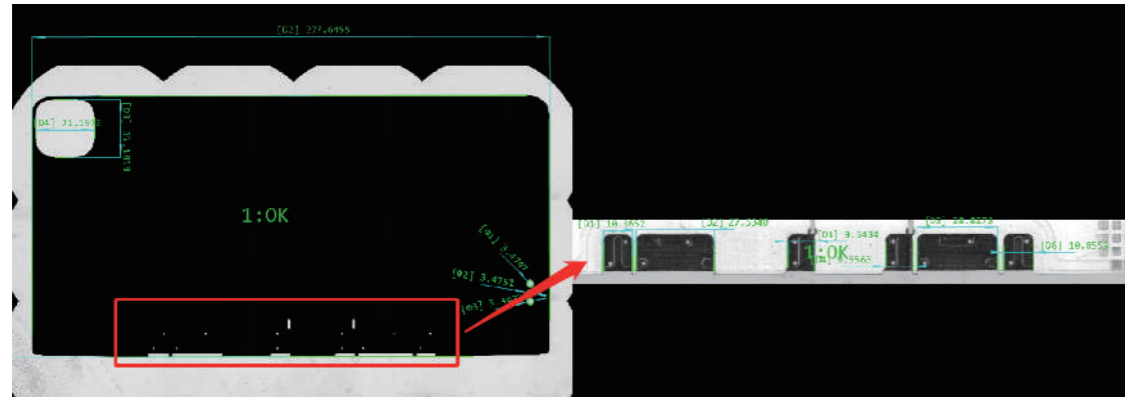

Software can combine two programs with different measurement views of the test object as a Conjoint one. During CNC measurement, two sub-programs can be performed sequentially on different views, then all data can be generated to a single measurement record for easy data management and statistic.

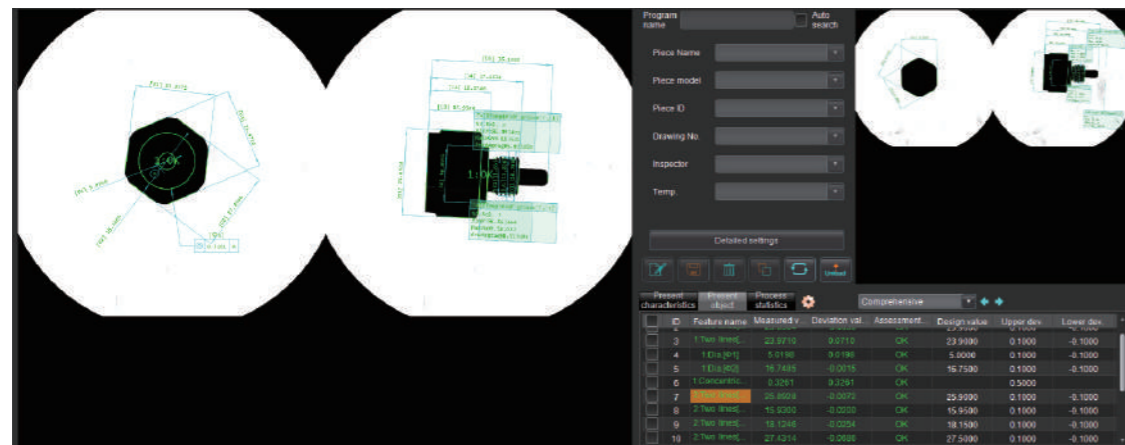

Barcode Scanner

The barcode value which is read by Scanner can be saved as inspection information, or used to search program according to definition of the operator.

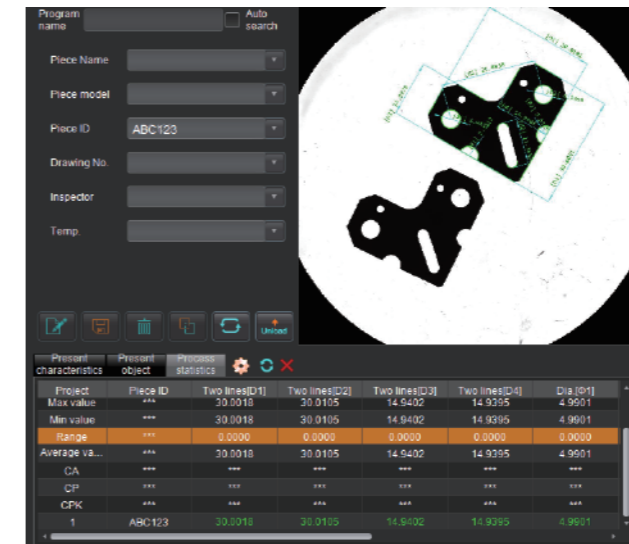

User Management

The accounts can be defined as administrator or operator, and user rights of the operator account could be constrained according to requirement.

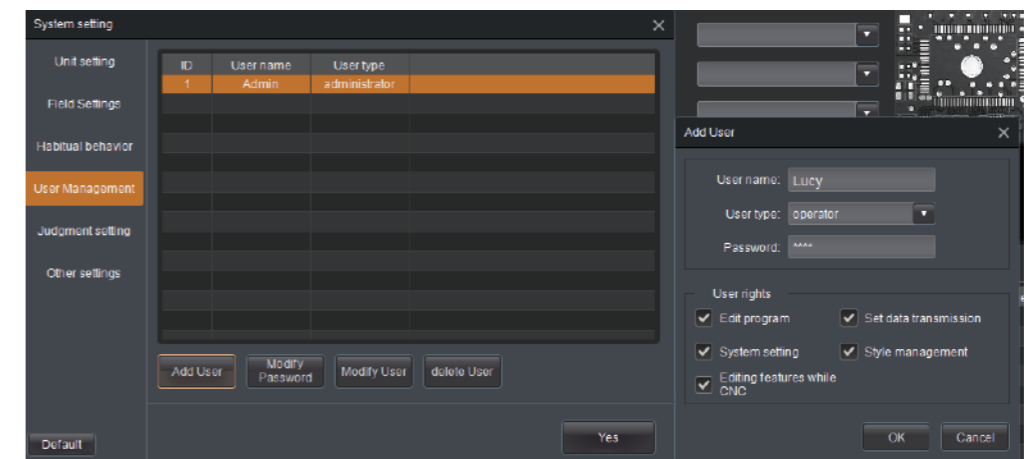

Statistical Analysis

The statistical analysis interface has the tabs of [Statistical Value], [Trend Chart], [Histogram] and [Data List]

Automatic recording and sorting

Measurement results and its main statistical information (e.g. average value, σ , 3σ , 6σ , Ca, Cp, Cpk etc) will be automatically recorded and saved. Operator could search records by different conditions.

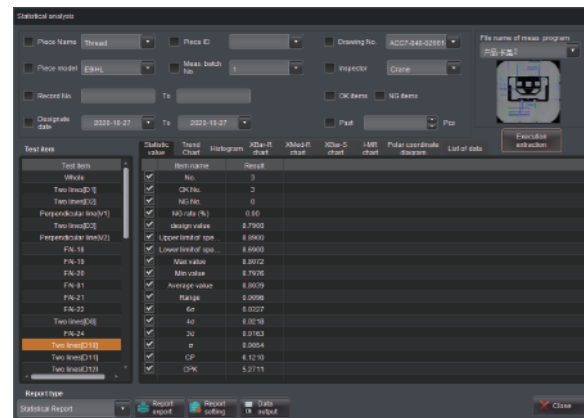

Statistic

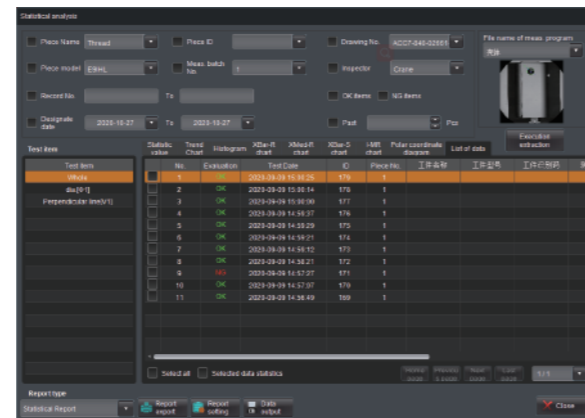

Tabled data

Control production process and improve product quality

The trend chart monitors the abnormalities of generating equipment and production process by regularly changing trend of measured values. Such as the monotonic and periodic changes of the measured values.

The histogram reflects the fluctuation and distribution of product quality, and transmits information about process quality, which can be used to judge and predict product quality and unqualified rate.

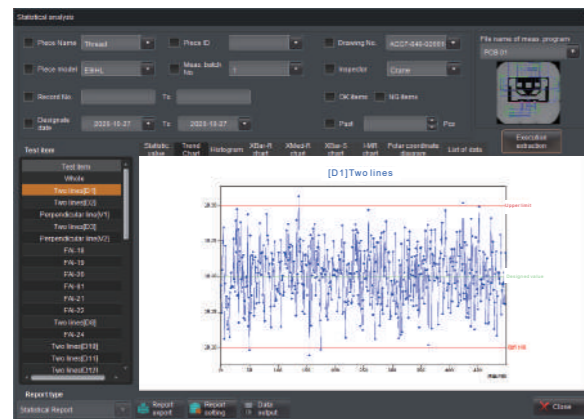

Trend Chart

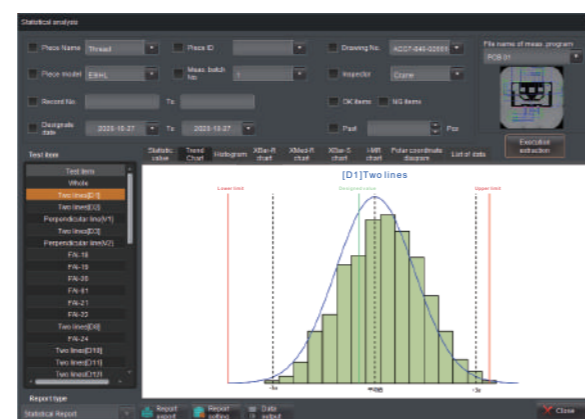

Histogram

By quality diagnosis and analysis, SPC statistical method can not only realize the monitoring of product quality, but also reflect the change trend in the generation process, reduce the waste caused by post-inspection, so as to achieve the effect of controlling the production process and improving product quality.

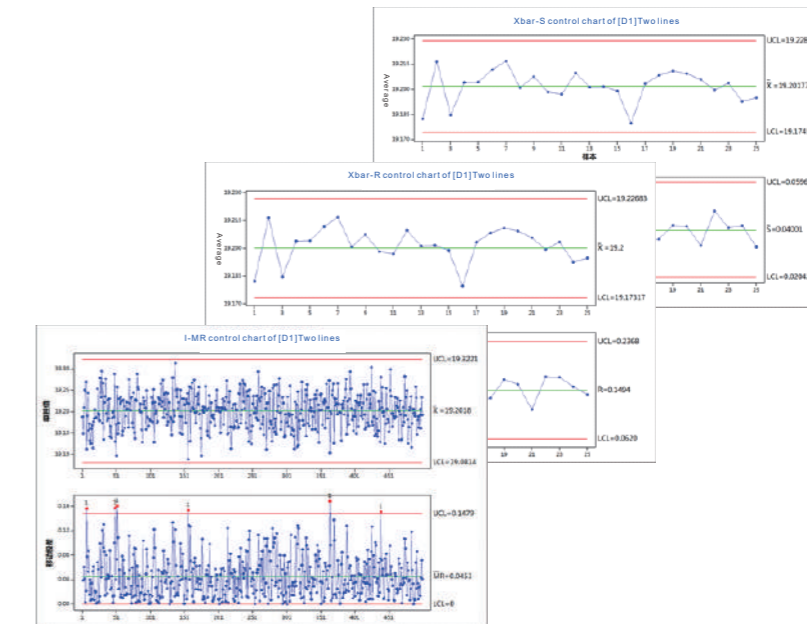

Control Charts

Generate measurement report automatically by One Key

1. Import and export Measurement records
2. Able to saved as PDF, CSV, Excel ,text files
3. Support user-defined PDF report template
4. Support user-defined Excel report template
5. Quick export and print reports by one key

Test Report						
						Date: 2020-03-20 10:20:08
						Object: SIM Card Tray#1
						Model: SW-W75
						Operator: ML
						Quantity: 1
						Temp.: 25
No.	Feature	Unit	Measured Value	Nominal	Upper Dev.	Lower Dev. Judge
1	5	mm	0.944	1.010	0.030	-0.030 NG
2	17-1	mm	14.811	14.830	0.070	-0.050 BK
3	17-2	mm	14.833	14.830	0.070	-0.050 BK
4	18-1	mm	15.097	15.100	0.070	-0.070 BK
5	18-2	mm	15.119	15.100	0.070	-0.070 BK
6	19	mm	39.840	39.840	0.050	-0.070 BK
7	15	mm	25.877	26.820	0.050	-0.080 NG
8	11a1	mm	25.882	26.820	0.050	-0.080 NG

Test report

Evaluation Methods

Standard Tolerance

Evaluate the measured values against the given design value and upper/lower tolerances specified on the drawing.

ID	Feature name	Measured value	Assessment result	Design value	Upper dev.	Lower dev.
1	Two lines[D1]	14.0731	OK	14.0700	0.0500	-0.0500
2	Dia [Φ1]	16.0572	OK	16.0500	0.0500	-0.0500
3	Point position-X[X1]	0.1999	OK	0.2000	0.0500	-0.0500
4	Point position-Y[Y1]	9.5467	OK	9.5500	0.1000	-0.1000
5	Positional alignme...	0.0066	OK		0.1000	
6	Concentricity[Φ1]	0.0094	OK		0.1000	
7	Dia [Φ2]	17.9649	OK	17.9600	0.0500	-0.0500
8	Vertical[Y1]	19.7949	OK	19.8000	0.0500	-0.0500

Grade of Tolerance

Divide the tolerance into multiple grades according to deviation range. Evaluate the sample's grade based on the actual measured value; If the dimensions of a sample are not in the same grade, this sample is unqualified. Classifying samples into different grades facilitates assembly and reduces waste.

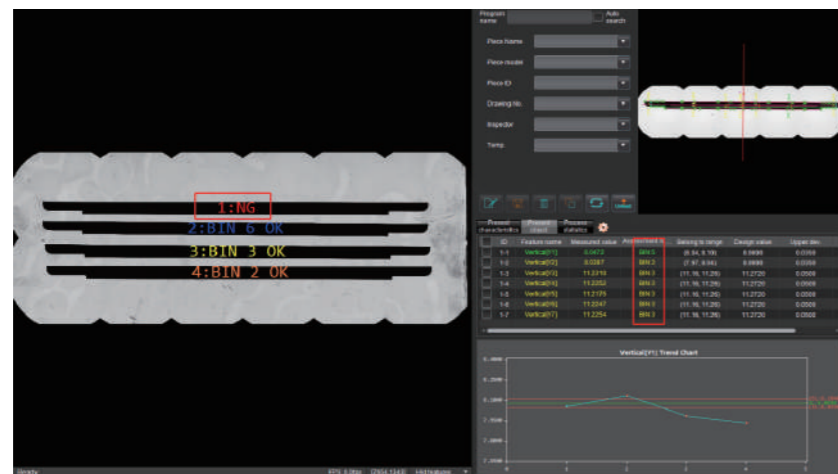
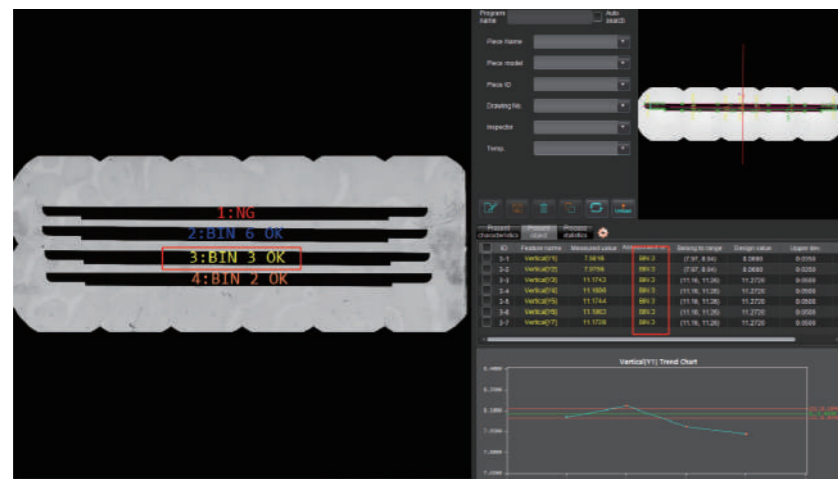

Proportion of Tolerance

Divide the tolerance into multiple grades according to tolerance percentage. Evaluate the sample's grade based on the actual measured value, so it can be used for pre-warning of processing equipment's state.

ID	Feature name	Measured value	Assessment result	Belong to range	Design value	Upper dev.
5-1	Two lines[D1]	14.0624	G1	(0.00%, 80.00%)	14.0700	0.0250
5-2	Dia [Φ1]	16.0396	G1	(0.00%, 80.00%)	16.0500	0.0250
5-3	Point position-X[X1]	0.2203	G2	(80.00%, 100.00%)	0.2000	0.0250
5-4	Point position-Y[Y1]	9.5129	G1	(0.00%, 80.00%)	9.5500	0.1000
5-5	Positional alignm...	0.0046	G2	(80.00%, 100.00%)		0.1000
5-6	Concentricity[Φ1]	0.0093	G1	(0.00%, 80.00%)		0.1000
5-7	Dia [Φ2]	17.9727	G1	(0.00%, 80.00%)	17.9600	0.0250
5-8	Vertical[Y1]	19.7822	G1	(0.00%, 80.00%)	19.8000	0.0250

Critical Dimensions

The sample is qualified by only Critical Dimensions which are specified by the operator.

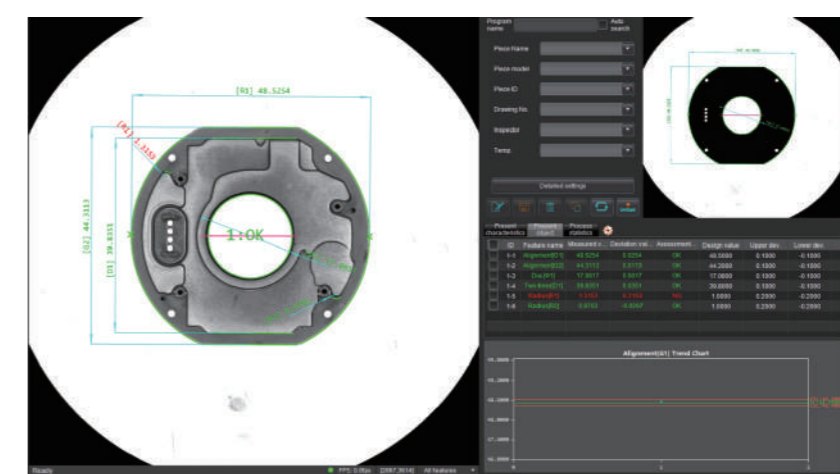
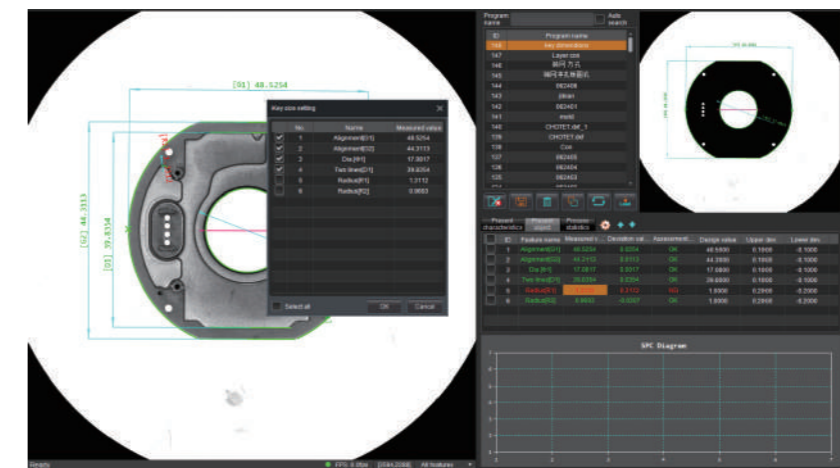

■ Data

Test reports can be generated simple and fast, such as PDF, WORD, EXCEL, CSV and TXT.

■ Process Statistics

Automatically calculate Cp and Cpk. Real-time trend chart or histogram display quality trends and changes during measurements.

■ Custom Excel Report

Measurement data & corresponding test images and inspection info are automatically exported into a designated Excel template in real time.

Customer		LOT No	
Part name		Material	
Part No.		Spec.	

Batch No.	Item	Measured value	Design Value	Upper Limit	Lower Limit	Inspector	Date
D8X62723-E75-P-N-1	L①	2.513	2.5	0.2	-0.2	Crane	09.20
D8X62723-E75-P-N-1	L②	2.512	2.5	0.2	-0.2	Crane	09.20
D8X62723-E75-P-N-1	L③	2.511	2.5	0.2	-0.2	Crane	09.20
D8X62723-E75-P-N-1	L④	2.508	2.5	0.2	-0.2	Crane	09.20
D8X62723-E75-P-N-1	L⑤	2.509	2.5	0.2	-0.2	Crane	09.20
D8X62723-E75-P-N-1	L⑥	2.511	2.5	0.2	-0.2	Crane	09.20
D8X62723-E75-P-N-1	L⑦	2.513	2.5	0.2	-0.2	Crane	09.20
D8X62723-E75-P-N-1	L⑧	2.512	2.5	0.2	-0.2	Crane	09.20
D8X62723-E75-P-N-1	L⑨	2.509	2.5	0.2	-0.2	Crane	09.20
D8X62723-E75-P-N-1	W①	1.999	2	0.3	-0.1	Crane	09.20
D8X62723-E75-P-N-1	W②	1.997	2	0.3	-0.1	Crane	09.20
D8X62723-E75-P-N-1	W③	1.998	2	0.3	-0.1	Crane	09.20
D8X62723-E75-P-N-1	W④	1.997	2	0.3	-0.1	Crane	09.20
D8X62723-E75-P-N-1	W⑤	1.997	2	0.3	-0.1	Crane	09.20
D8X62723-E75-P-N-1	W⑥	1.999	2	0.3	-0.1	Crane	09.20
D8X62723-E75-P-N-1	W⑦	1.996	2	0.3	-0.1	Crane	09.20
D8X62723-E75-P-N-1	W⑧	1.999	2	0.3	-0.1	Crane	09.20
D8X62723-E75-P-N-1	W⑨	1.997	2	0.3	-0.1	Crane	09.20
D8X62723-E75-P-N-1	H①	0.901	0.9	0.1	-0.1	Crane	09.20
D8X62723-E75-P-N-1	H②	0.904	0.9	0.1	-0.1	Crane	09.20
D8X62723-E75-P-N-1	H③	0.904	0.9	0.1	-0.1	Crane	09.20
D8X62723-E75-P-N-1	H④	0.903	0.9	0.1	-0.1	Crane	09.20
D8X62723-E75-P-N-1	H⑤	0.902	0.9	0.1	-0.1	Crane	09.20
D8X62723-E75-P-N-1	H⑥	0.905	0.9	0.1	-0.1	Crane	09.20
D8X62723-E75-P-N-1	H⑦	0.901	0.9	0.1	-0.1	Crane	09.20
D8X62723-E75-P-N-1	H⑧	0.903	0.9	0.1	-0.1	Crane	09.20
D8X62723-E75-P-N-1	H⑨	0.901	0.9	0.1	-0.1	Crane	09.20

■ TCP

Measurement data is transmitted to the MES system of the customer via socket or HTTP protocols in real time.

VisionX also could receive commands from the external server to load the program and begin measurement, so it is compatible with robotic arms to achieve unmanned measurements.

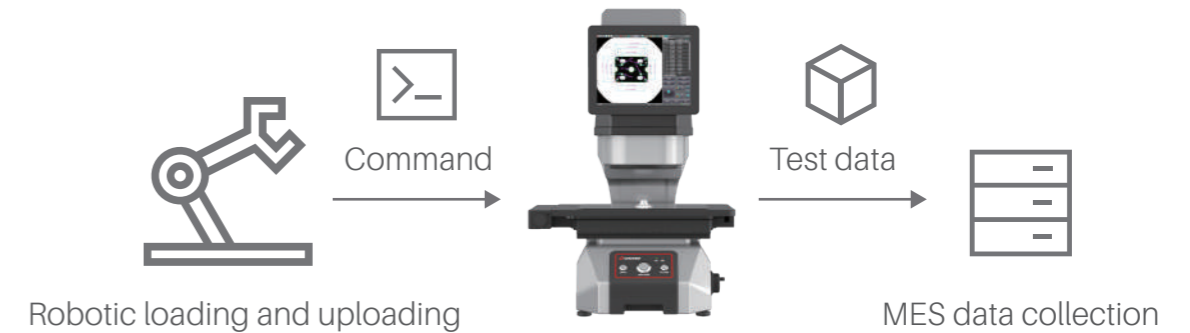

■ QDAS

Automatically generate test results in a format which can be recognizable by the QDAS system.

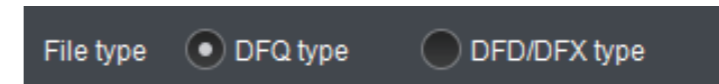

K fields can be customized to link VX machines to output parameters.

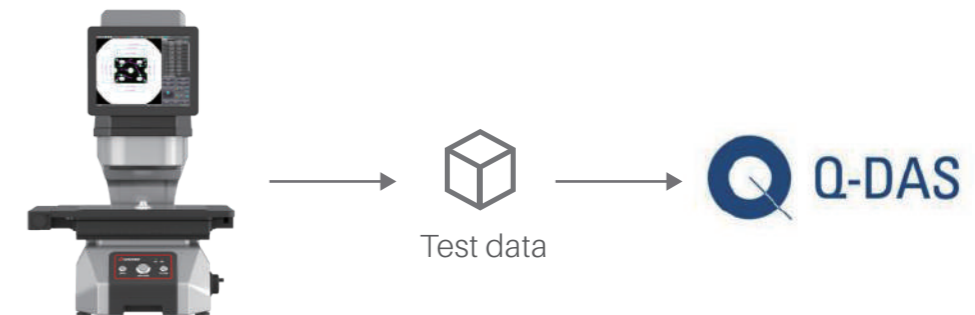

Custom Text Report: Operator can define the content format of the report in Text file, and the measurement data are exported in real time.

Baseline-Line Distance

There are three options for baseline-line distance annotation. Select the desired line and annotate it with a single click.

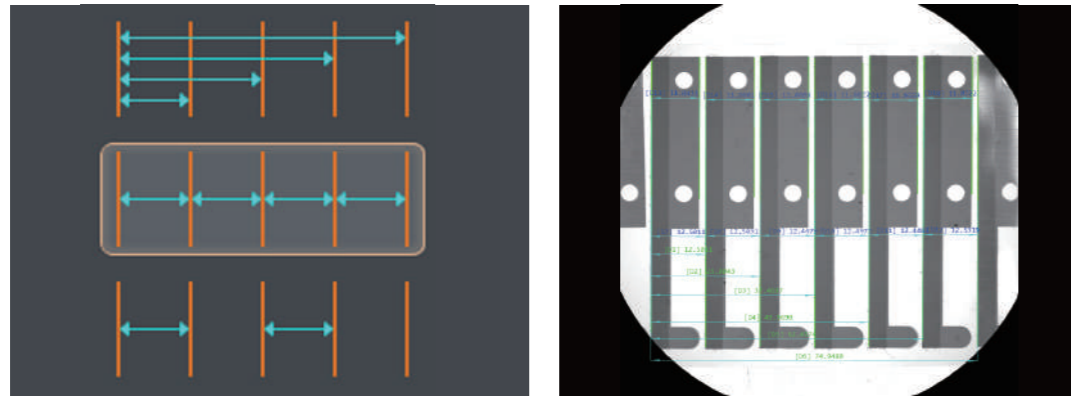

Auto Edge Detection

Simply highlight the region where the feature is located, and the system will automatically capture the edge.

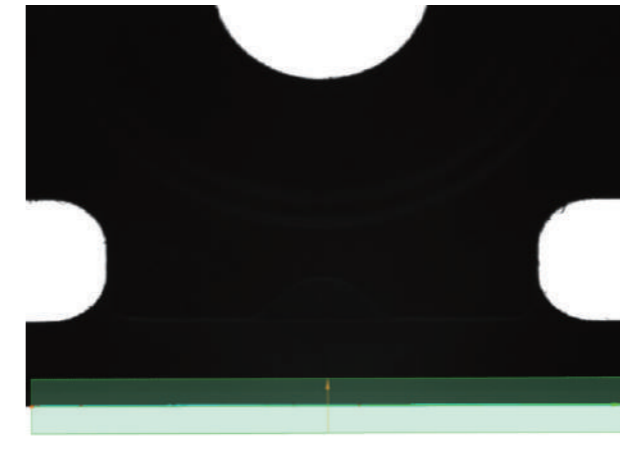

Intelligent Annotating

This tool can annotate distance between two points or two lines, center distance between two circles, max distance or min distance or center distance between line and circle, etc.

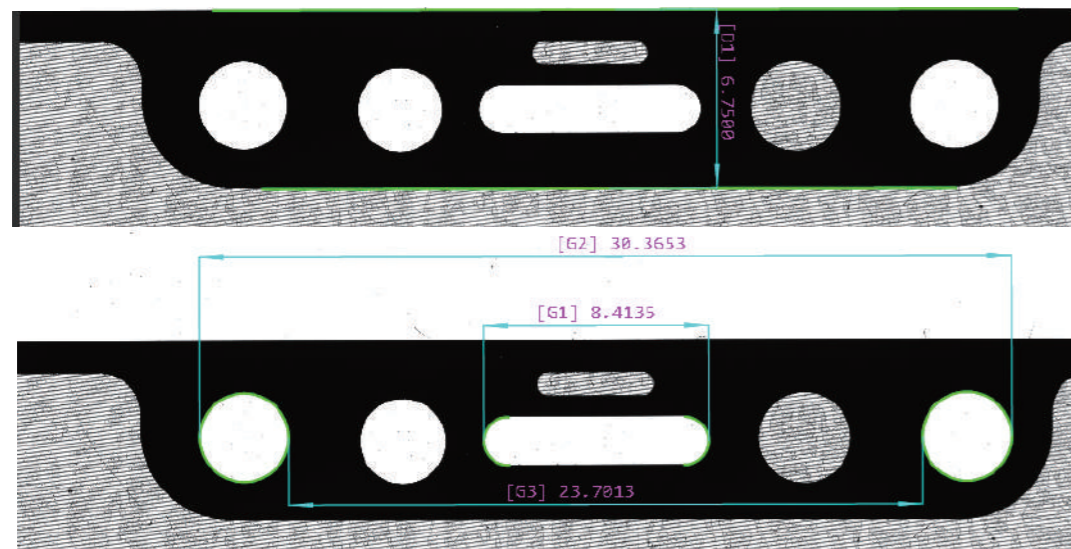

Various edge extraction conditions can be set to exclude interference and accurately extract the target feature, even for tiny boundaries.

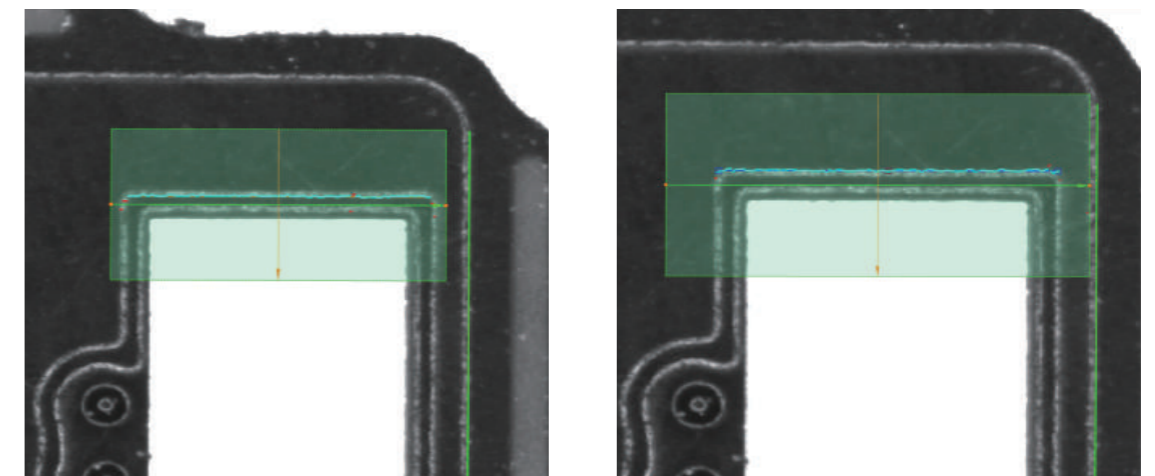

Extract from bright to dark

Extract from dark to bright

Auto deburring

Automatically remove abnormal points to eliminate the interference of edge burrs, and extract features accurately.



Even if boundary is discontinuous, the system can eliminate interference from nearby features. Complex settings are not required as the system automatically removes abnormal points.

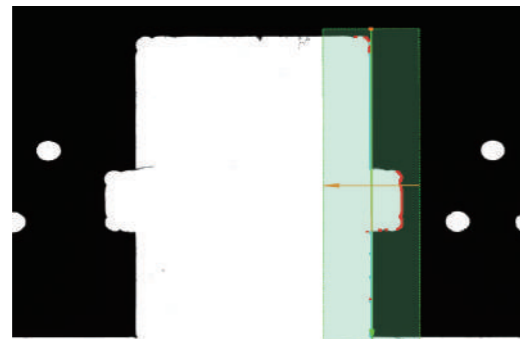

The arcs at both ends of a straight line can also be automatically excluded

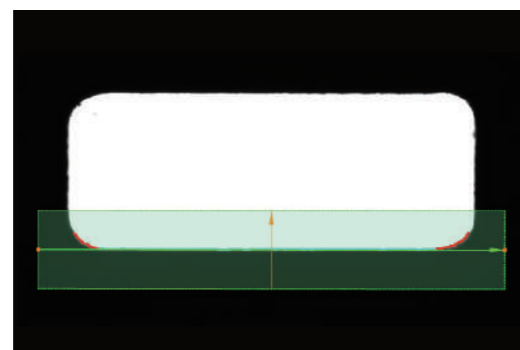

Posture Adjustment

The posture adjustment function automatically adjusts the orientation of the lasso to ensure precise feature extraction. Even if the lasso does not contain the target feature appropriately, the system automatically adjusts the posture of the lasso to center on the feature.

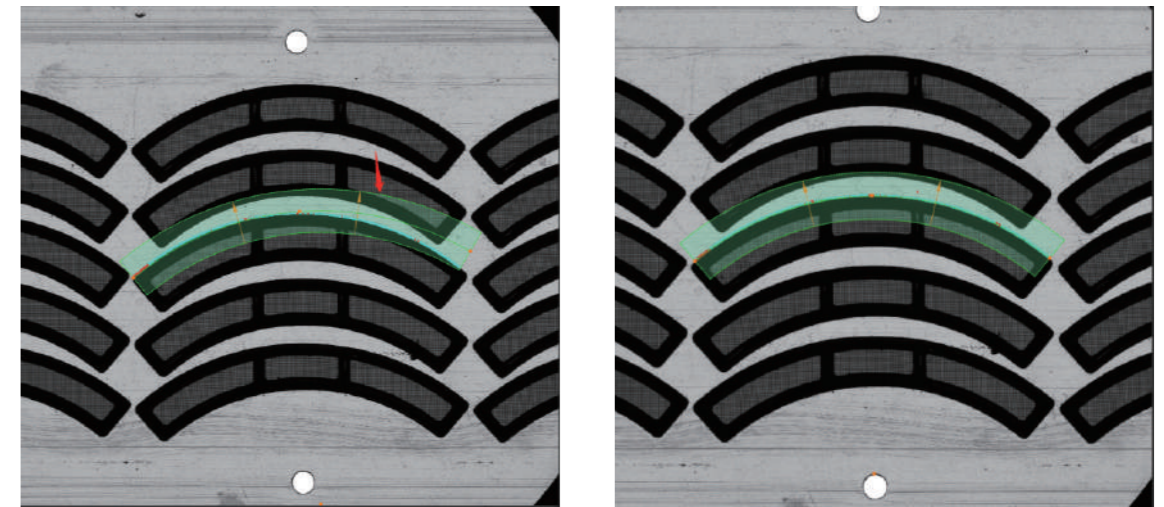

Free selection

After auto adjustment

For the measurement of peak point, the operator can set condition to constrain orientation of the lasso to ensure accurate calculation of peak value.



Before posture adjustment

After posture adjustment

Sieve Measurement

Multiple measurements can be made continuously, and the report can be output with the deviation values.

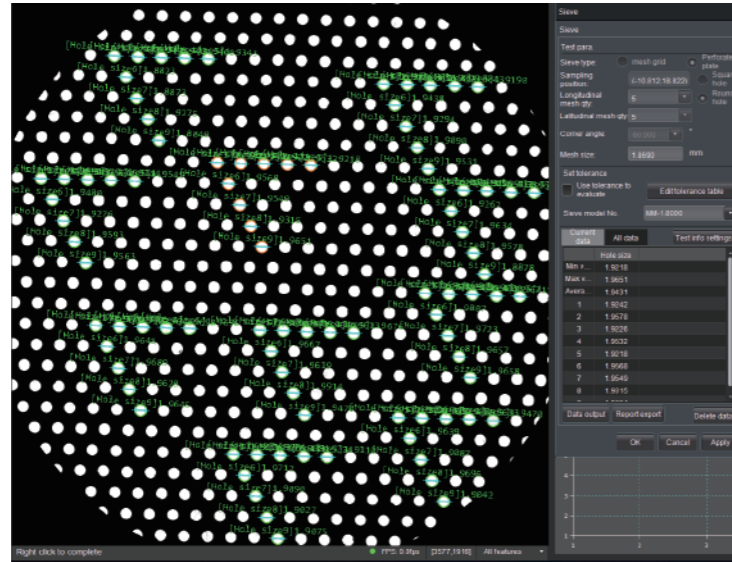

Circles

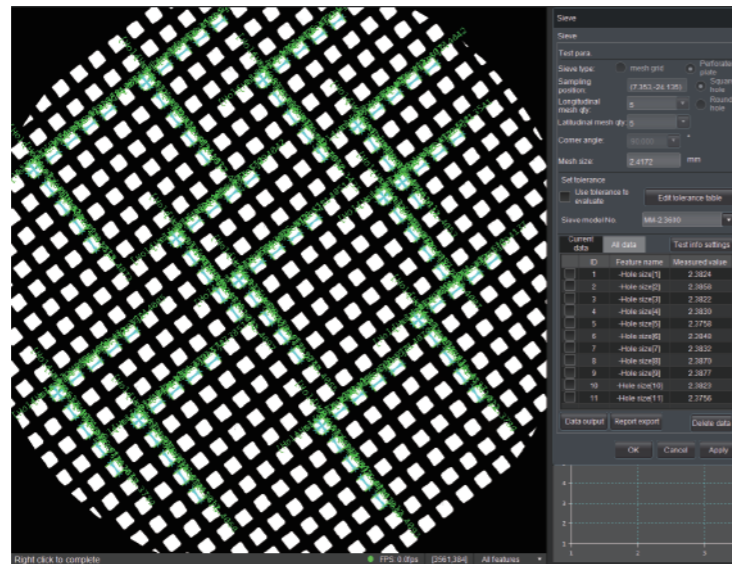

Squares

Gear/R Gauge Measurement

- Gear parameters can be measured in as fast as 2 seconds, such as pitch distance, tooth spacing, normal line, tooth runout, etc. Splines also can be measured by this tool, and both internal and external gears/splines can be measured.

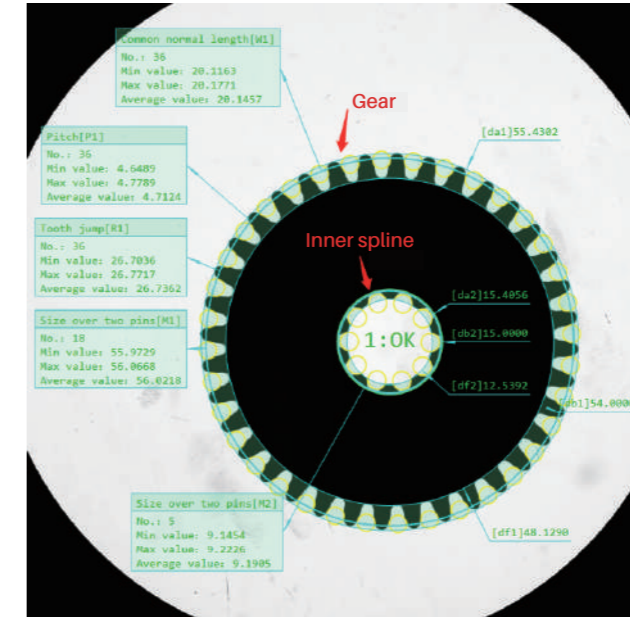

Gear

- No need to create a program. Place the objects on the table then click Measure.

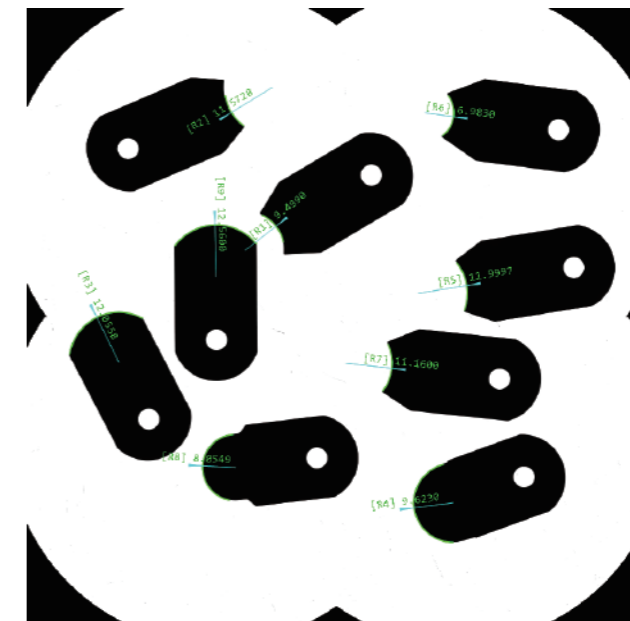

R Gauge

Application

Flash measuring machines are widely used in industry of machinery, electronics, mold, injection molding, hardware, rubber, low-voltage electrical appliances, magnetic materials, precision stamping, connectors, connectors, terminals, mobile phones, home appliances, printed circuit boards, medical equipment, watches, tools, etc.



Phone case Phone accessories Watch inner parts Watch chain Machining parts

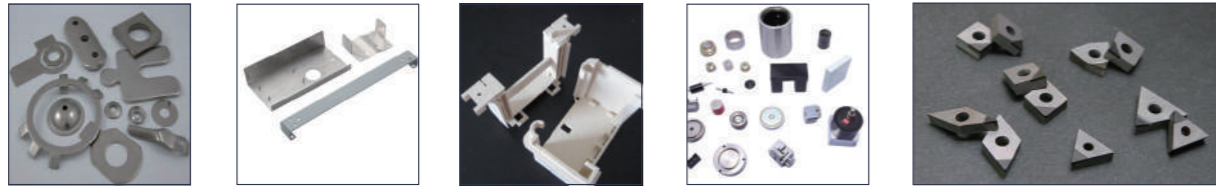

Stamping parts Sheet metal parts Plastic injection parts Magnetic component Cutting tools

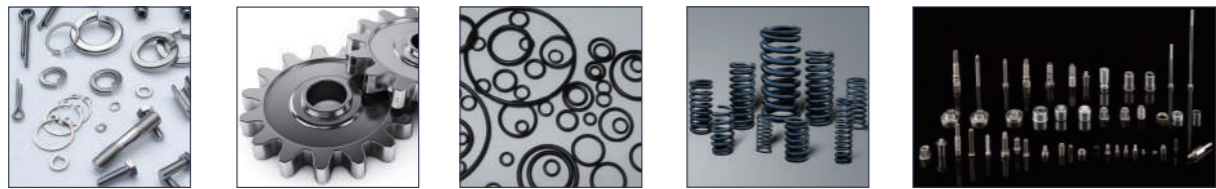

Small metal parts Gear Rubber ring Spring Thread, Shaft

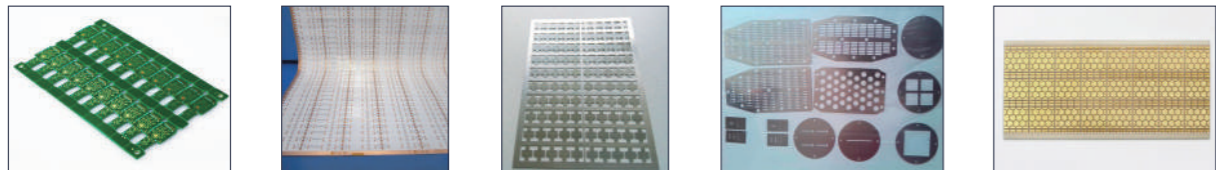

Rigid PCB Soft PCB Shielding case Mask board Ceramic plate



Car monitor frame Connectors Battery Resistors Filter mesh



Die cutting Medical drill Sieve Radius gauge Thread template

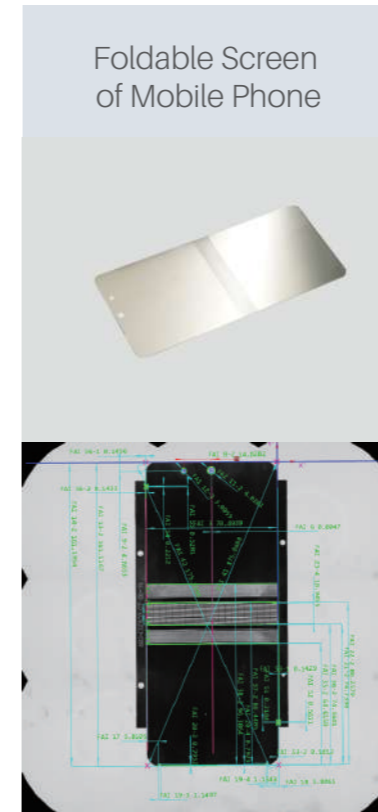

Foldable Screen of Mobile Phone



Phone Casing

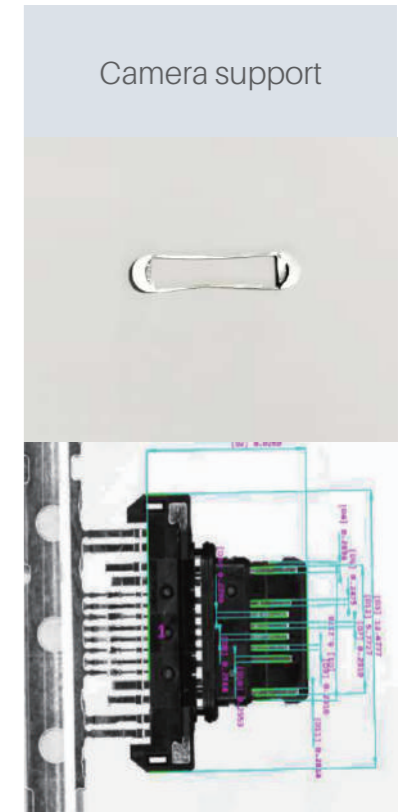

Camera support



Shield slot



Back Cover Glass of Mobile Phone

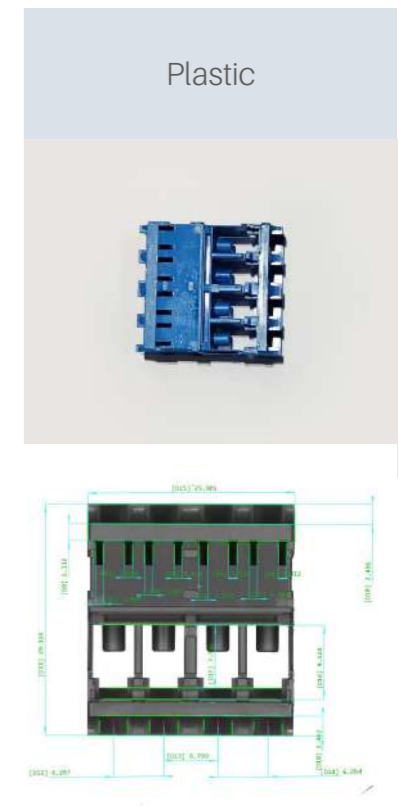

Plastic

Terminal

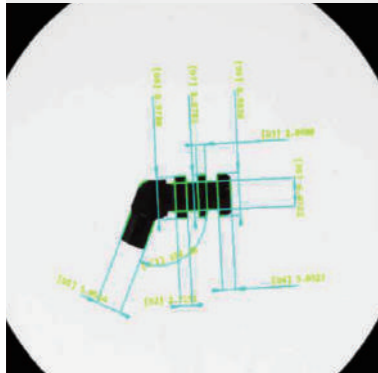

Shielding Covers

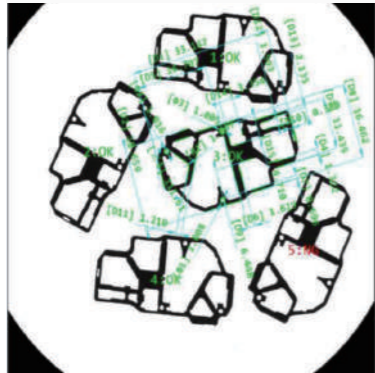

Resistors

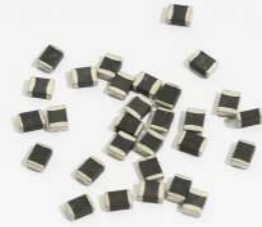

Type-C Charging Port

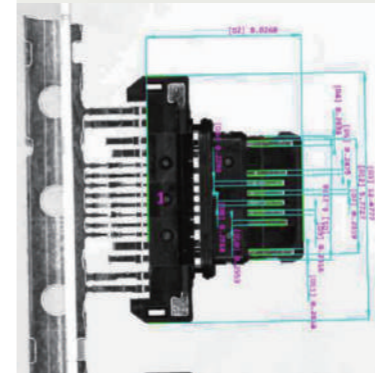
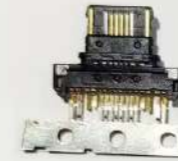

Medical drill

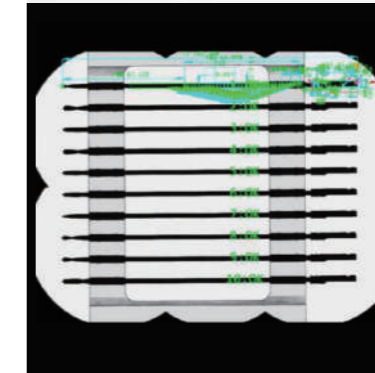

Filter

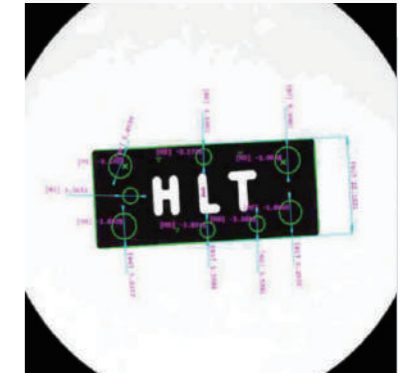

Die Cutting

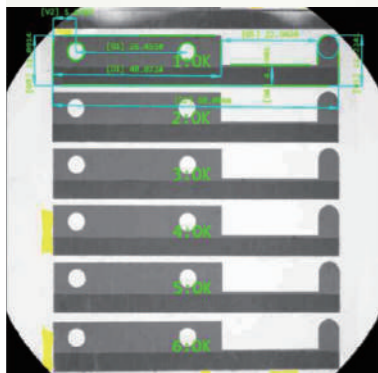
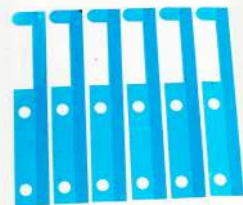

Sockets

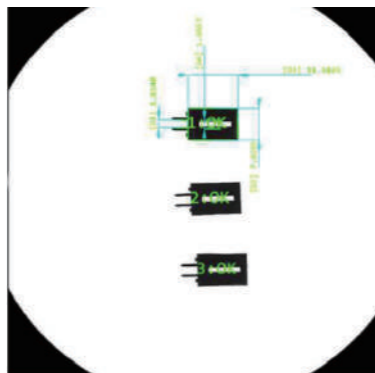

Magnetic Component

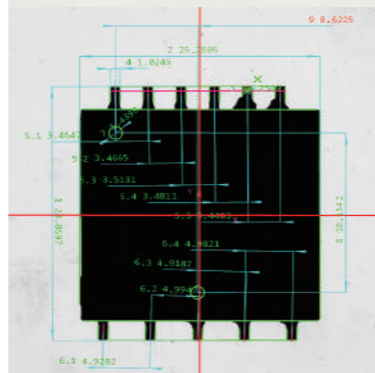

Connector

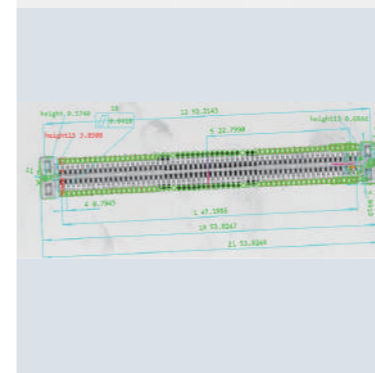

Parking Pawl

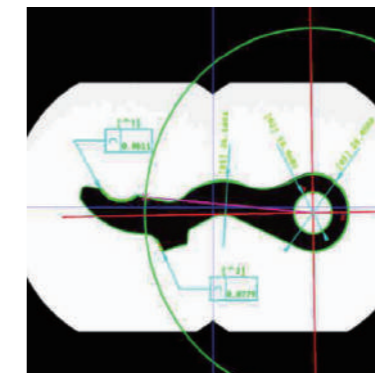

Soft PCB

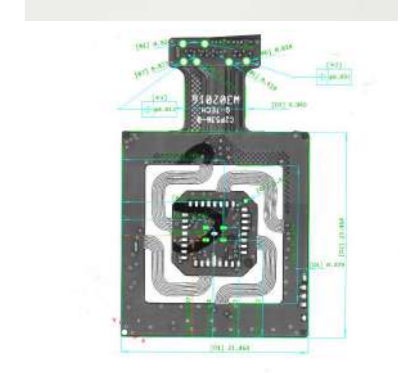

VX8100/VX8200/VX8300

Imaging by 20 million pixel CMOS is clearer
Rotary chuck is available for 360° measurement of cylindrical samples



Rotary chuck



Parameters

Model No.		VX 8100	VX 8200	VX 8300	VX 8306D
Image Senor		20MP CMOS			
Monitor	Built-in	10.4" LCD (XGA:1024x768)			
	Outside	24" LCD (XGA:1920x1080)			
Acceptance Lens		Double Telecentric Lens			
Light	Ring Light	Four-segment illumination(White Light)			
	Back Light	Telecentric transmission illumination(Green Light)			
	Coaxial Light (optional)	LED directional light			
F.O.V.	Large Field(mm)	200x100 (4 Angles R50)	200x200 (4 Angles R50)	300x200 (4 Angles R50)	230x130 (4 Angles R50)
	High Precision(mm)	130x20	130x130	230x130	216x116
Resolution		0.1 μm			
Repeatability of Image Meas.	Wide Field	Without Stitching*1	±1 μm		±0.5 μm
		With Stitching*2	±2 μm		±1 μm
	High Precision	Without Stitching*1	±0.5 μm		±0.1 μm
		With Stitching*2	±1.5 μm		±0.5 μm
Accuracy of Image Meas.	Wide Field	Without Stitching*1	±3 μm		±2 μm
		With Stitching*2	±(5+0.02L) μm		±(4+0.02L) μm
	High Precision	Without Stitching*1	±1.5 μm		±0.7 μm
		With Stitching*2	±(3+0.02L) μm		±(2+0.02L) μm
Horizontal Rotary Unit (Optional)	Rotation Angle	Range 360°, Resolution 0.02°			
	Rotation Speed	0.2~2rev/s			
	Max Diameter	Φ 60mm			
Height Meas. (Optical Probe) (Optional)	Measuring Range(X*Y)		120*110mm		
	Max Depth/Diameter(H/Φ)		1.64		
	Dia. of Beam		Φ100μm(Φ18μm optional)		
	Resolution		0.25 μm		
	Z Non-movement	Range(Z)	±2mm		
		Accuracy	±2 μm		
Z Movement	Range(Z)	75mm			
	Accuracy	±(6+0.01H) μm, H is Z movement height in mm			
XY Object Table	X Travel Range		110mm	210mm	
	Y Travel Range		/	110mm	
	Loading Capacity		2kg	7.5kg	
Z-Axis Travel Range		35mm	75mm(Motorized)		
Size(LxWxH) mm		500x280x670	531x386x731	531x503x731	
Weight		30kg	49kg	75kg	
Input		AC100~240V,50/60Hz, 2A, 300W			
Working Environment		Temp.10 °C~35 °C, Humidity 20~80%, Vibration<0.002g, Less than15Hz			

Remark :

* 1 In the focus position, the environment temperature is +20 °C ± 1.0 °C

* 2 In the focus position, the environment temperature is +20 °C ± 1.0 °C, and the load on the table is 2 kg or less;
L is the moving range of the table (mm)

VX1060/VX1100



Parameters

Model No.	VX1060	VX1100
Image Sensor	20MP CMOS	
Monitor	24" LCD (XGA:1920×1080)	
Acceptance Lens	Double Telecentric Lens	
Light	Ring Light	Four-segment illumination(White Light, Manual up & down)
	Back Light	Telecentric transmission illumination(Green Light)
F.O.V.	Φ60mm	Φ100mm
Repeatability of Image Meas.	±1μm	±1μm
Accuracy of Image Meas.*1	±2μm	±3μm
Software	VisionX	
Resolution	0.1μm	
Z axis travel Range	35mm	
Loading Capacity	3kg	
Size(L×W×H)	500×280×670mm	
Weight	25kg	
Input	AC100-240V, 50/60Hz, 2A , 300W	
Working Environment	Temp. 10°C~35°C, Humidity 20~80%, Vibration<0.002g, Less than15Hz	

Remark :

*1 In the focus position, the environment temperature is +20 °C ± 1.0 °C

VX4230S/VX4230

No stitching measurement, any position on object able.
Ideal for measurement of phone case and big accessories.



Parameters

Model No.	VX4230S	VX4230
Image Sensor	25MP CMOS	12MP CMOS
Outside Monitor	24" LCD (XGA:1920×1080)	
Acceptance Lens	Double Telecentric Lens	
Transmission Illumination system	Parallel transmission illumination(White Light)	
F. O.V.	Φ230mm	200x150mm
Depth of Field	50mm	50mm
Working Distance	400mm	
Repeatability of Image Meas.	±2μm	
Accuracy of Image Meas.*1	±5μm	
Z Axis Travel Range	65mm	100mm
Software	VisionX	
Resolution	0.1μm	
Loading Capacity	15kg	
Size(L×W×H)	830×605×2030mm	
Weight	375kg	370kg
Input	AC100-240V,50/60Hz, 4A,600W	
Working Environment	Temp.10°C~35°C, Humidity 20~80%, Vibration<0.002g, Less than15Hz	

Remark:

*1 In the focus position, the environment temperature is +20 °C ± 1.0 °C

VX5100

No need workholder
Ideal for measurement of thread and shaft

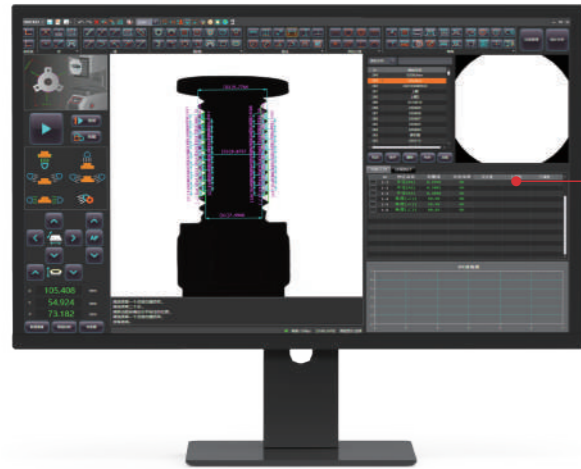

Vision X software



One-Touch Button

Double Telecentric Optical Lens

Motorized Object Table

Parameters

Model No.	VX5100	
Image Sensor	5MP CMOS	
Outside Monitor	24" LCD (XGA : 1920×1080)	
Acceptance Lens	Double Telecentric Lens	
Transmission Illumination System	Telecentric transmission illumination(Green Light)	
F. O. V.	φ100mm	
Repeatability of Image Meas.	±2μm	
Accuracy of Images Meas.*1	±5μm	
Software	VisionX	
Resolution	0.1μm	
XY Motorized Object Table (Optional)	Rotational Speed	0.2 Revolution/s~2 Revolutions/s
	Diameter	φ60mm
	Loading Capacity	3kg
Size(L×W×H)	(736×200×325)mm	
Weight	25kg	
Input	AC100-240V,50/60Hz,1.3A,150W	
Working Environment	Temp.10 °C~35 °C, Humidity 20~80%, Vibration<0.002g, Less than15Hz	

Remark:

*1 In the focus position, the environment temperature is +20 °C ± 1.0 °C

VX8500

Large measuring range



Parameters

Model No.		VX8500		
Image Sensor		20MP CMOS		
Monitor		24"LCD(XGA:1920x1080)		
Acceptance Lens		Double Telecentric Lens		
Light	Ring Light	Four-segment illumination(White Light/Green light)		
	Back Light	Telecentric transmission illumination(Green light)		
F.O.V.	Large Field	500x400mm(4 Angles R50)		
	High Precision	430x330mm		
Resolution		0.1μm		
Repeatability of Image Meas.	Wide Field	Without Stitching ^{*1}	±1μm	
		With Stitching ^{*2}	±2μm	
	High Precision	Without Stitching ^{*1}	±0.5μm	
		With Stitching ^{*2}	±1.5μm	
Accuracy of Image Meas.	Wide Field	Without Stitching ^{*1}	±3μm	
		With Stitching ^{*2}	±(5+0.005L)μm	
	High Precision	Without Stitching ^{*1}	±1.5μm	
		With Stitching ^{*2}	±(3+0.005L)μm	
Horizontal Rotary Unit (optional)	Rotation Angle	Range 360°, Resolution 0.01°		
	Rotation Speed	0.2~2rev/s		
	Max Diameter	Φ60mm		
Height Meas. (Optical Probe) (Optional)	Measuring Range(X*Y)		300*300mm	
	Max Depth/Diameter(H/Φ)		1.64	
	Dia. of Beam		Φ100μm(18μm Optional)	
	Resolution		0.25μm	
	Z Non-movement	Range(Z)	±2mm	
		Accuracy	±2μm	
	Z Movement	Range(Z)	200mm	
Accuracy		±(6+0.01H)μm, H is Z movement height in mm		
XY Object Table	X Travel Range		410mm	
	Y Travel Range		310mm	
	Loading Capacity		20kg	
Z-Axis Travel Range		200mm(Motorized)		
Size(LxWxH)		(900x1340x1600)mm		
Weight		950kg		
Input		AC200-240V,50/60Hz, 10A,2500W		
Working Environment		Temp.10 °C~35 °C, Humidity 20~80%, Vibration<0.002g, Less than 15Hz		

Remark:

*1 In the focus position, the environment temperature is +20 °C ± 1.0 °C

*2 In the focus position, the environment temperature is +20 °C ± 1.0 °C, and the load on the table is 2 kg or less;

L is the moving range of the table (mm)

Hybrid series



Precision Bridge-Type Structure

Double Telecentric Optical Lens

High Definition Motorized Zoom Lens

Intelligent Programmable Lighting System

Parameters

Model No.		Hybrid432	Hybrid682
Travel range	X	400mm	600mm
	Y	300mm	800mm
	Z	200mm	200mm
Structure Type		Column	Moving Bridge
Base Material		Granite	
Monitor		24" LCD (1920x1080)	
Resolution of Glass Scale		0.1μm	
Guide Rail		Precision linear guide rail	
High-resolution Electric Zoom Lens	Lens	13.3X Motorized lens	
	Magnification* ¹	Optical zoom: 0.6~8.0X, Image Zoom: 17~232X	
	Image Sensor	HD colorful industrial camera	
	Single F.O.V.	1mm×1mm~12mm×12mm	
	Measuring Range	360×310mm	610×800mm
	Meas. Accuracy (XY)* ²	(1.8+L/200)μm	(2.2+L/200)μm
	Meas. Accuracy (Z)* ³	(2.8+L/200)μm	
	Bottom	Telecentric transmission Illumination (Green Light)	
	Ring	6 rings and 8 segments light (White light)	
	Coaxial Light	LED light	
Double Telecentric Wide F.O.V. Optical Lens	Lens Spec.	Φ100mm double telecentric lens	
	Single F.O.V.	90×90mm	
	Measuring Range	460X330mm (4 Angles R50)	580X800mm (4 Angles R50)
	Accuracy of Single F.O.V.* ⁴	±4μm	
	Stitching Accuracy* ²	(4+L/200)μm	(6+L/200)μm
	Back Light	Telecentric transmission Illumination (Green)	
Ring Light	4 segments illumination (White light, 75°), directional ring light (Green light, 0°)		
Max Speed	XY	500 mm/s	
	Z	200 mm/s	
Size		910×1350×1700mm	1600×1860×1700mm
Weight		700kg	2300kg
Loading Capacity		25kg	50kg
Power Supply		2000W	2500W
Motion Control		Servo control system	
Software		Vision X	
Input		AC200~240V, 50/60Hz	
Working Environment		Temp. 20°C±2°C, Humidity 20~80%, Vibration<0.002g, Less than 15HZ	

Note :

*1 Image magnification is approximate and depends on monitor size and resolution.

*2 In the focus position, the environment temperature is +20 °C ± 1.0 °C, and the load on the table is 5 kg or less; L is the moving range of the table in mm.

*3 It is mechanical accuracy, and actual accuracy depends on object surface where lens focuses.

*4 In the focus position, the environment temperature is +20 °C ± 1.0 °C.